

Label by laser print

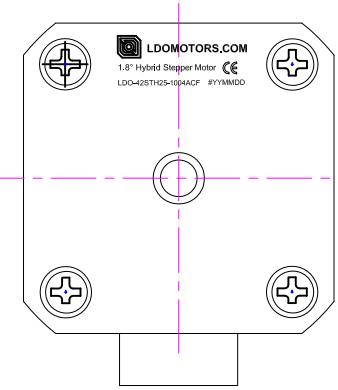

Diagram

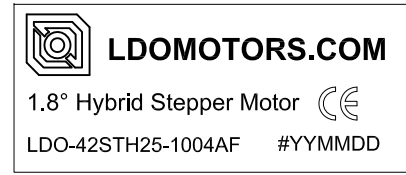
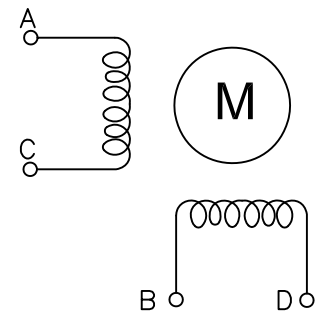

Items	Specs	Items	Specs
Phase Number	2 phases	Step Angle	1.8° ±0.09°
Rated Voltage	DC 5.5V	Rated Current	DC 1 A / Phase
Resistance(20°C)	5.5±10% Ω / phase	Inductance	7±20% mH / Phase
Holding Torque	≥200mN.m	Detent Torque	10mN.m REF.
Rotate Direction	A-AB-B- CW	MAX Starting PPS	1300 PPS
MAX slewing PPS	≥ 1600 PPS	Insulation Resistance	≥ 100 MΩ (DC 500V)
HI POT	AC600V/1mA/1S	Insulation Class	<b>Class F 155°C</b>
Rotor Inertia	34 g.cm²	Weighth	0.152 Kg REF.

REV	ECN NO	Description	Made by	Approve	Date
A	---	New Release.	SD XU	J. B.	11/22/18

		<b>LDO MOTORS CO.,LTD</b>			
		<b>Hybrid Stepper Motor LDO-42STH25-1004AF(BDT)</b>			
Des.	Check	Appr.	Date	Factory Code	page

A

B

C

D

A

B

C

D

1

2

3

4

5

6

1

2

3

4

5

6